

CONVECTION OVENS & MODULAR DECK OVENS



577, rue Célestin Hennion - 59144 GOMMEGNIES
tél. +33.(0)3.27.28.18.18 - fax. +33.(0)3.27.49.80.41
www.eurofours.com - infos@eurofours.com

FABRICANT 
EUROFOURS[®]

6 stakes, your 6 advantages



« « Convection ovens are part of our history at Eurofours Company. They are our roots, our present time and our future. Pierre Lancelot, founder of the company, has been the first to introduce convection ovens with a baking quality unrivalled nowadays. He was the leader of what became Eurofours today. That is why since more than 30 years our position is the one of the leaders. Our philosophy is targeted around two simple ideas: To preserve our historical industrial know-how and to introduce innovations which can meet the requirements of our customers »



◀ (59 North of France) *Stéphane and Nicolas Lancelot*
That is where our history starts...



Today, the production of the Eurofours range is shared between 4 sites representing more than 12000 m2.



Energy savings

The energy is part of the environment of the baker, we have focused on energy control. The energy performance is an electric consumption brought up to what you precisely need, while you can achieve the right quality and perfect baking for your products.

The Green environment

We aim at developing the most comfortable oven when you use it. Have a look and see how we have taken care of the cleaning of the windows, at the right visual indications of the information on the control board,... we show respect for our customer, and it is obvious to think that the oven must be developed in respect of the rules where it leads to a pleasant job.

Ergonomy







We aim at developing the most comfortable oven when you use it. Have a look and see how we have taken care of the cleaning of the windows, at the right visual indications of the information on the control board,... we show respect for our customer, and it is obvious to think that the oven must be developed in respect of the rules where it leads to a pleasant job.

Esthetic

Color can come in option. Stainless steel is our standard process. We have forecasted to put over the assembly front frame different colors which can be chosen (black, red, white or chosen at your own convenience). That color touch is baked and is rather resistant and easy to maintain.

Applied a coat of paint to a stainless steel support bring to your oven something different from any other oven and takes part from your decoration in your lab. You can ask for personal color paint. We will propose you a budget and a realization which will meet your expectations.

Standard	
	stainless steel
Option	
	stainless steel + black epoxy
	stainless steel + red epoxy
	stainless steel + white epoxy
	stainless steel + epoxy + personal touch

6 stakes, your 6 advantages

Guarantee and Quality

We paid the greatest attention at the choice of our components and obviously made a drastic selection of our suppliers. Our components have been tested severely, and our baking tests have been operated with professional bakers. Materials have been correctly selected because of our long experience. Our Quality department is focused on controlling 38 main points for each oven before shipment.



The quality it is just 3 years warranty on any parts of the oven except consumable parts like glass door, gasket, bulbs, silicon...).

Eurofours is ISO 9001 labeled since more than 17 years. Any range displayed in our catalogue meets the following standards: CE, NSF, Metus, Metcdn, Gost... (or is being approved).



The regular monitoring of our process and components by external and independent laboratories just show to our customers that our quality is reliable and gets the right conformity next to the high level requirements of the international markets.



Efficiency and Multi-use

The Viennoiserie and bread assortment offer keep increasing. The flour network channel capacity to innovate in the field of the ingredients, process, recipes and ended products compels respect. Eurofours is going part of the way for those evolutions and is building electrical or gas convection ovens which can meet those new requirements. The multi-use capacity becomes a main choice criterion. Our ovens are able to respond at a full range of products: From sweet and delicate pastries to heavy and specific breads with thick crust. From any kind of 500 grs bread and more to a viennoiserie range to keep continuing with specific products like macarons or meringues, at any time those products require specific baking and our range can cope with such level of requirements.

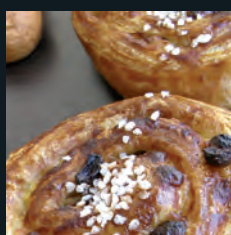
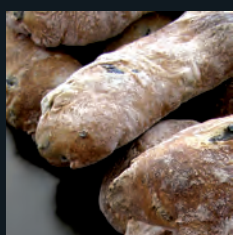
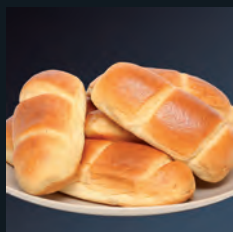

In that field and that is the reason why such various companies are using our ovens in their kitchen laboratory development to adjust their recipes for their products. Very famous chains of stores or bakers are using our ovens to bake their specific products while their names and reputation are committed.

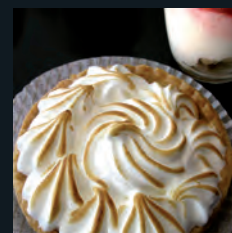

Just get your imagination as a limit!

Convection ovens: use and function



Control board



The e-drive board is a touch screen control board integrated in the front face of the oven.

It allows using all the oven's functions, either by saving up to 99 programs, or by using the manual mode.

Ultra intuitive, with a rapid access to settings for a daily use, and also an easy online access to program and save recipes via an internet connection or per a USB connection, e-drive is the control board we recommend you for its simplicity and its many possibilities. Enjoy a friendly regulation as a smartphone!

* available soon

◀ readable screen is 60x100mm or 4,5"



USB connection



Internet connection*

Energy consumption

Electrical energy is known for its flexibility of different baking and can be managed also within your production needs all day long.

Eco Functions ensures a real flexibility. Thanks to our half-load system, you can activate only half of the heating elements when the oven is loaded less than 50% of its capacity.

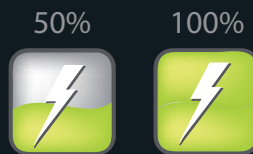

1



2



Insulation

Paying great attention to the insulation of the oven is not only important with regard to energy saving, but it is also a main contributor to the baking quality.

The insulation materials we use will remain enduring and efficient for the life time of the oven.

Our tests make evidence that the insulated external sides remain at a maximum temperature of 20° degrees Celsius above the environment temperature. (1)

This is possible by using the best and most suitable materials. (Stabilized and reinforced fiberglass 45mm thick)

Double glass door (6mm thick each) with air circulation in between, allows to lower (reduce) the external surface temperature. (2) It complements the oven's insulation device and avoids any risks of burn.

Convection ovens: use and function



Playback works:

E-drive shows at a glance the settings during the baking.

Recipes, temperature, remaining time, ventilation..., you will get at any time an easy access to all functions.



Programming recipes:

Temperature, baking time, percentage of steam injection, and many other settings are available for each recipe. In order to use with simplicity the oven with the e-drive control board, the most standard recipes have been preloaded. Offering you in a simple way the possibility to modify the parameters to match your expectations.

A touchscreen for professionals:

Ultra reliable, the e-drive control board is made for a baking environment. No more hassle! Dough and flour will not affect the electronic panel. Just a simple cleaning to use it for a while! Our strong relationship specifications are contracted and bound with our suppliers for performance level and bakery use.



! The control board RUNI is also available. It is also a touchscreen >

Air Flow Control

Reinforced stainless steel electrical heating elements specially designed to match our specific fan, are tested and controlled before assembling.

(1, 2, 3) The fan is designed to fit (to adapt) the size of the baking chamber. Our fan bears 36 or 40 shaped blades. These blades are properly sized, from 50mm to 70mm, according to the oven model. The heat is channeled through our lateral perforated steel sheet, and streamed by the vacuum system at the back of the baking chamber. (4) We keep the airflow at a low and regular speed, to bake in a gentle atmosphere. The fan speed can be lowered to bake small and light products, thanks to a speed variator option, named Pastry Kit.



Steam

The solenoid valve, which controls the water injection on a steam device, permits to explode "THE JET" and diffuses into the baking chamber wet steam (fog). Avoiding direct contacts between water and heating element, this technology guarantees important moisture and preserves the longevity of heating elements, which are not suddenly cooled down. Moreover, the injection nozzle does not require any maintenance. However, depending on the water quality from your network we just recommend you to add a purifier.

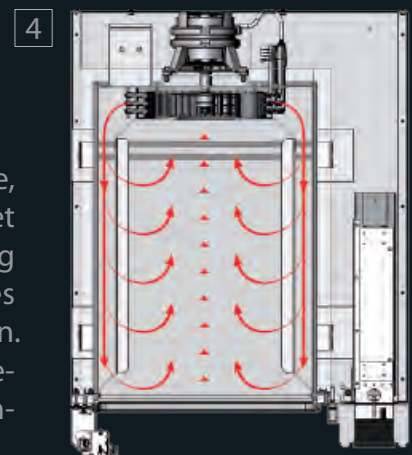

Convection ovens: hygiene and comfort

Glass cleaning

Well-cleaned glass combined with good lighting in the baking chamber insures good vision of the products. Without any tool you can easily remove two side screws inside the oven. Thus, released it allows you cleaning the both sides of each glass in a short time and with little efforts.



Door opening system

Well sized and mounted door handle guarantees you comfortable feeling when taking it in hand. Sturdy, it is designed to support up to 10,000 openings per year. Optionally this handle can be equipped with a system of locking/ unlocking by electromagnetic lock. Without any efforts you can unlock the door of the oven. The handle is needed just to pull and to push the door for opening and closing into the position of locking by electromagnet. Our clients confirm that this system became for them a great solution very comfortable to use and for us it became the most reliable system on the market.

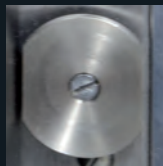

As an option, the system of locking and unlocking by electromagnetic lock.

Door seal

For our convection ovens we use door seals for high temperatures attached by clipping it inside. It is extremely easy to remove and to place the door seal manually for cleaning or replacing purposes. No glue needed.



Smells elimination

When sugar and salt products go one after another it is better that their odors won't be mixed. Thanks to our "Odor control" device you can by simple push on the button remove the rest of odors between two bakings. This feature is available for all convection and modular deck ovens which are equipped with steam option. This simple system allows the elimination of almost 100% of scents left in the baking chamber.



Convection ovens: hygiene and comfort

Quick-load system

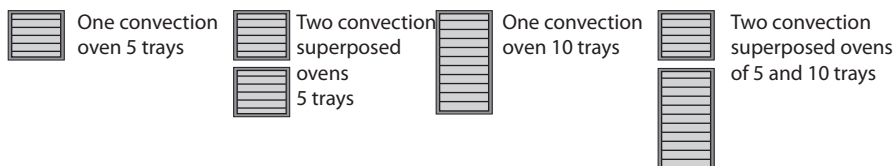

Illustration of system functioning
Oven design is not contractual
Trolley is identical whatever the combination is

Being available for the convection ovens 5 and 10 trays landscape format with dimensions of 600x400mm (stacked or not) Quick-load system offers you rapidity and comfort of loading the ovens in a unique way. The trolley (equipped by closing curtain for hygienic reasons) allows you by single movement load and unload all the trays into the oven.

Quick and hygienic!

Quick →
← **Load**
system



Autowash system

That system is available for 4 and 5 trays capacity electric convection ovens in order to simplify for you the cleaning of the oven. Can be simply launched from control board, the process of washing includes 5 cycles: pre-wash, wash, pre-rinsing, rinsing up and drying. The spray nozzle retracts in the end of the washing cycle what allows using the total loading capacity of the oven. In addition, our washing system is compatible with most of the detergents.



Snacky, 3 in 1 oven



Available in 4 trays capacity with dimensions 400x800 the oven Snacky combines 3 baking modes: 1. baking with grill (to offer your clients the product with thin cheesy crust "au gratin"). 2. Ventilated baking (even baking and coloring for pastry). 3. Baking on the refractory stone ideal for baking bread and or pizza.

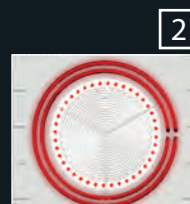
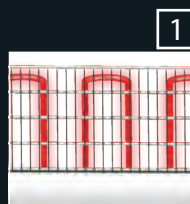
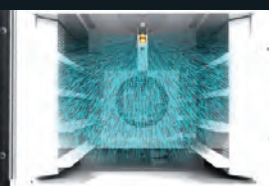
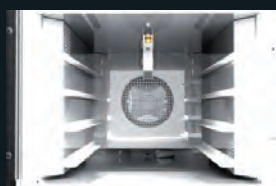

Modular deck ovens: use and function

e drive



readable screen ►
is 60x100mm
or 4,5"

* available soon

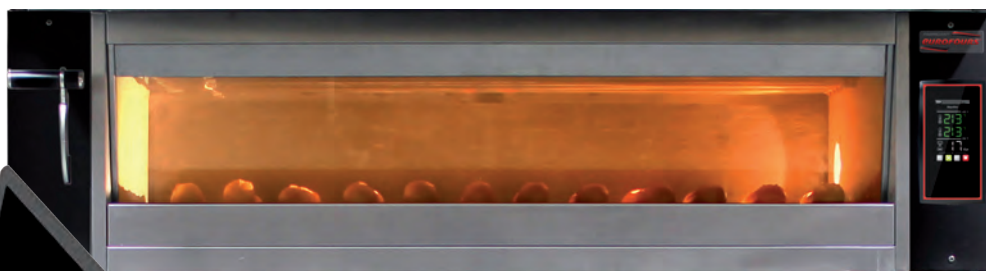

The e-drive control board

The e-drive control board is a touch-sensitive screen integrated in the front face of the oven.

It allows you to go through the menus or to use in manual mode all the functions of the oven. Ultra intuitive, with an easy and rapid access for a daily use, very on-line to program and register recipes via an internet connection* or by USB key, well in hand to use it manually. The e-drive control board we recommend you for its simplicity and its multiple possibilities.

Enjoy a friendly regulation as a smartphone!



USB connection



Internet connection*



Heating elements and insulation

The hairpin shape heating elements with a diameter of 10 mm are made in refractory armored stainless steel. The power of each is adapted to the type of oven to ensure a perfect distribution of heat from the front to the back and from the right to the left. Their number varies within the size of oven and corresponds to our purpose of obtaining a very dense meshing in order to expose the bread to an optimized radiation. They are securely held by omegas which function consists in protecting them from possible knocks of shovel.

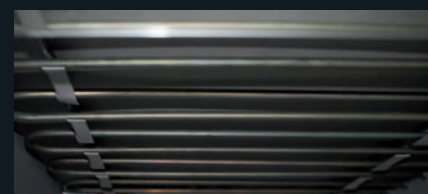

Rockwool insulation covered with a rigid film all around the baking chamber combined with tight sealing of the door reduce considerably the heat losses by contributing to energy and particularly important heat mass saving in order to provide you with a smooth and uniform cooking.

Modular deck ovens: use and function



Programming recipes and their use:

Temperature, baking time, percentage of steam injection, and many other settings are available for each recipe. In order to enable you simple start for using the oven with the e-drive control board the most standard recipes have been preloaded, however you can easily modify the parameters to match your preferences. Finally, in order to manage your production, you could program a postponed start.

A touch screen for professionals

Ultra reliable, the e-drive control board is made for a baking environment. No more hassle! Dough and flour will not affect it. Just a simple cleaning to use it for a while! Our strong relationship specifications are contracted and bound with our suppliers for performance level and bakery use.



Efficient regulation :

The oven is equipped with two temperature probes per deck. The alternating regulation of top and bottom allows reducing the power connection while keeping the oven baking performance.

Stone baking dec



The bakery is moving towards very slow fermentation methods. The dough is increasingly stored in containers at a temperature of 3 to 5 °C. The baking stone plays an extremely important role in reaching a perfect baking result. Our modular deck ovens are equipped with slabs made by ourselves in an ancestral process. The thickness is 25 mm, which places them among the thickest of the market, they are designed to resist to the abrasion of their surface. They are reinforced by a metallic mesh and rimmed in a stainless steel frame for stability ever time. The heating element powers ensure that stone high inertia and a perfect heat distribution. The stone on which you put down the bread ensures rapid transfer of heat to the heart of your products. The water is drained away on our micro porous deck. The result is an optimum strong product development in the oven. Our stone baking deck is a method and a manufacturing quality process which enhance your baking quality.

Modular deck oven: hygiene and comfort

Glass cleaning

Clean glass with a good light inside the oven ensures you a good visibility for your products. Without tools you can operate by yourself the glass position (1) to turn it in a cleaning position (2). From that position, you can easily clean your glasses both sides.

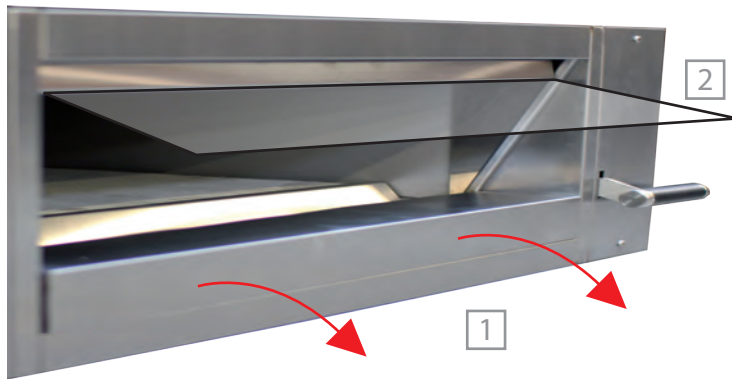

Ergonomic handle

The handle is designed to be comfortable to operate.

A simple movement from the upper to the lower position allows blocking the glass door in the upper position. Maintenance and adjustment are not necessary for this process. It prevents from dust introduction into the oven back sides.



Steam distribution system

The steam distribution system is made from refractory steel 10 mm thickness. In the lower position steel frame pieces strengthen the mass and give you a heavy steam all day long. The injecting pipe easy to remove for maintenance makes 17 mm diameter.

Just to get more steam, the water is injected on the upper side of the frame to provide abundant and humid steam. The heating elements are placed directly in contact with external steel frame for better heating conduct. They are not directly in the water for a better longevity and efficiency.

The steam comes from the back of the oven. That humid steam condenses in an even way and very fast reaches your products.

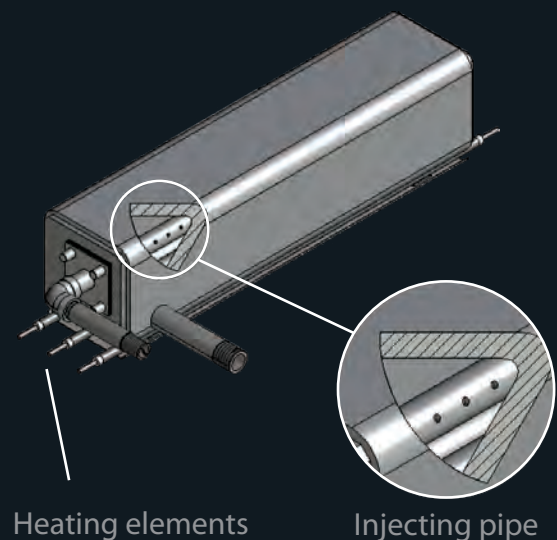
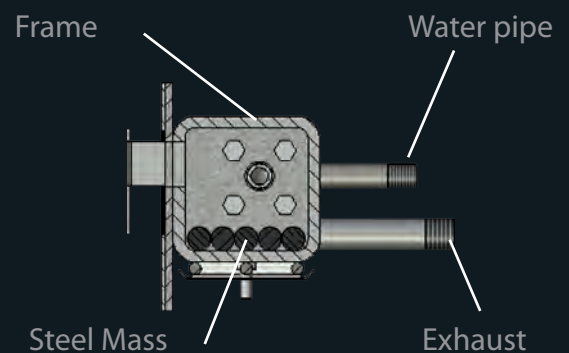

Modular deck ovens : polyvalent and modular

Baking in front of the customers

This range of pastry and bakery ovens is made to be set up inside the shop with its own integrated loader and to propose you several solutions:

- The compactness of our range allows you to set it up in front of the customers inside the bakery shop.
 - A baking surface from 2.5 to 9 m²
 - An ergonomic and a comfortable use make especially women pleased when they use it without any efforts.
 - Pastry trays 400x600 mm dimensions can be placed on the oven's loader that facilitates the process of putting in and removing the trays out of the baking chamber.
 - We are even carrying in our range the specific size 18x26 inches to meet the demand from North America and USA markets.
- A specific option has been developed for pizzas use and you can easily reach the necessary 400° Celsius for such products.

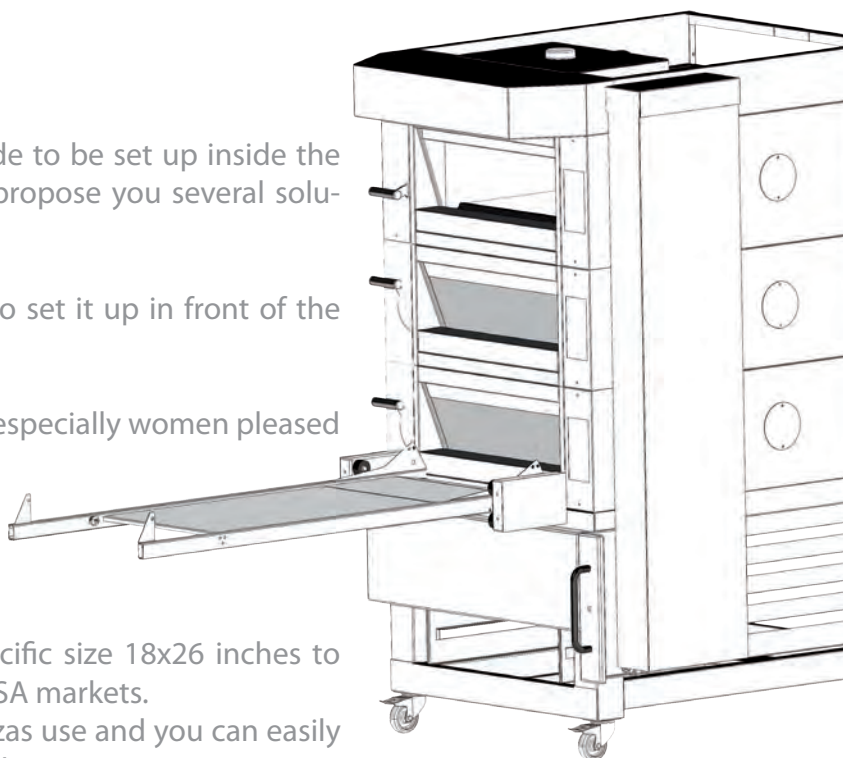

Dare the color!



Technical data: convection ovens

- foresee 250mm for technical access behind the oven
- foresee 250mm high for technical access from the top of the hood
- ! - steam drain nozzle without hood: Ø 76mm and with hood: Ø 153mm
- arrival and evacuation of water at 1m20
- space between trays : 85mm
- Hood : depth of the oven + 215mm in front



Right or left hinges to be confirmed with order

Electric convection 4 trays oven (mm) Spacing : 85mm

Trays capacity	400 x 600	400 x 800	460 x 800	600 x 400	460 x 660	660 x 460
Height	540					
Width	780		840	980	840	1040
Depth (handle + 60mm)	1025	1225	1225	825	1085	885
Depth with opened door	1615	1815	1815	1615	1735	1875
Weight (kg)	119	132	178	119	148	148
Electric power (with/without steam) : 5,8/10,2kW Heating power (with/ without steam) : 5,25/9,45kW Standard voltage : ~3x400V+N+T						

Electric convection 5 trays oven (mm) Spacing : 85mm

Trays capacity	400 x 600	400 x 800	460 x 800	600 x 400	460 x 660	660 x 460
Height	625					
Width	780		840	980	840	1040
Depth (handle + 60mm)	1025	1225	1225	825	1085	885
Depth with opened door	1615	1815	1815	1615	1735	1875
Weight (kg)	125	137	183	125	153	153
Electric power (with/without steam) : 5,8/10,2kW Heating power (with/ without steam) : 5,25/9,45kW Standard voltage : ~3x400V+N+T						

Electric convection 10 trays oven (mm) Spacing : 85mm

Trays capacity	400 x 600	400 x 800	460 x 800	600 x 400	460 x 660	660 x 460
Height	1080					
Width	780		840	980	840	1040
Depth (handle + 60mm)	1025	1225	1225	825	1085	885
Depth with opened door	1615	1815	1815	1615	1735	1875
Weight (kg)	200	225	245	200	215	215
Electric power (with/without steam) : 11,2/19,7kW Heating power (with/ without steam) : 10,5/18,9kW Standard voltage : ~3x400V+N+T						

Gas convection 5 trays oven (mm) Spacing : 85mm

Trays capacity	400 x 600	400 x 800	460 x 800	600 x 400	460 x 660	660 x 460
Height	625 (+287 with a chimney of Ø 153mm, what gives 912mm)					
Width	780		840	980	840	1040
Depth	1100	1300	1300	1160	900	960
Depth with opened door	1662	1862	1922	1782	1662	1782
Weight (kg)	135	147	193	163	135	163
Electric power : 0,65 kW - Standard voltage : ~ 3x400V+N+T						
Heating power with propane or natural gas : 11,5 kW - butane : 8,7 kW						

Combination examples
* Combination compatible with «QuickLoad System»

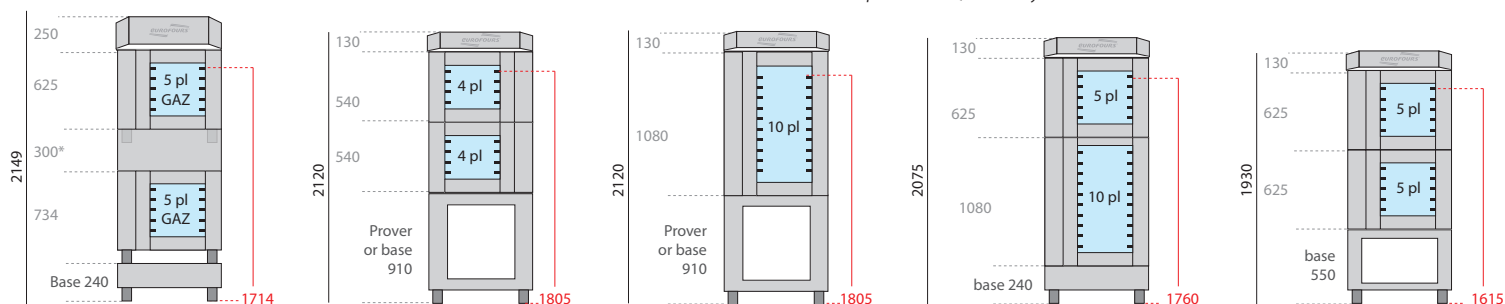

* support intermédiaire obligatoire

Technical data: accessories for convection ovens



Feet (90 to 130mm) or casters (130mm) when ordering
Right or left hinges to be confirmed with order

Provers (mm) Spacing : 70mm

	400 x 600	400 x 800	460 x 800	600 x 400	460 x 660	660 x 460
Quantity of trays	16	8	8	16	16	8
Height	910					
Width	780	840	840	980	840	1040
Depth (handle + 82mm)	1025	1225		825	1085	885
Depth with opened door	1750	1950	2010	1750	1870	
Weight (kg)	79		84	79	84	
Electric power 1,2 kW - Standard voltage : ~ 1x208-240V+N+T						

Provers (mm) Spacing : 63 mm

	400 x 600	400 x 800	460 x 800	600 x 400	460 x 660	660 x 460
Quantity of trays	16	8	8	16	16	16
Height	910					
Width	780	780	840	980	840	1040
Depth	1615				1735	
Depth with opened door	2395	2395	2455	2595	2575	
Weight (kg)	200					
Electric power 1,2 kW - Standard voltage : ~ 1x208-240V+N+T						

Tables (mm) Spacing : 70 mm

	400 x 600	400 x 800	460 x 800	600 x 400	460 x 660	660 x 460
Trays capacity						
Height	240 (0 étages), 550 (4 étages) ou 910 (8 étages) au choix					
Width	780	780	840	980	840	1040
Depth	920	1120	1120	720	980	780

Base (mm) 4 trays Spacing : 100 mm

	400 x 600	400 x 800	460 x 800	600 x 400	460 x 660	660 x 460
Trays capacity						
Width	780	780	840	980	840	1040
Depth	910	1110	1110	710	970	770
Height	550					

Technical data: modular deck ovens

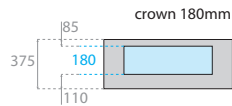
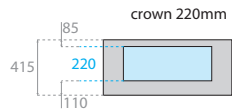

! Foresee 250mm of technical access behind the oven

Modular deck oven 2 trays



Capacity	400 x 600	400 x 800	600 x 400	460 x 660
Baking slab width x depth (mm)	830 x 610	830 x 810	660 x 810	950 x 670
Baking area (m ²)	0.50	0.67	0.53	0.63
Width (mm)	1150	1150	980	1270
Depth (mm) (steam: +125mm)	1025	1225	1225	1085
Electric power with/without steam	5.2 / 3.8 kW	5.9 / 4.5 kW	5.7 / 4.3 kW	5.2 / 3.8 kW

Modular deck oven 3 trays



Capacity	400 x 600	400 x 800	600 x 400	460 x 660
Baking slab width x depth (mm)	1240 x 610	1240 x 810	-	1420 x 670
Baking area (m ²)	0.75	1.00	-	0.95
Width (mm)	1560	1560	-	1740
Depth (mm) (steam: +125mm)	1025	1225	-	1085
Electric power with/without steam	7 / 5.6 kW	9.4 / 6.6 kW	-	7 / 5.6 kW



2 trays 600x800



4 trays 600x400

Modular deck oven 4 trays



Capacity	400 x 600	400 x 800	600 x 400	460 x 660
Baking slab width x depth (mm)	-	-	1240 x 820	-
Baking area (m ²)	-	-	1.02	-
Width (mm)	-	-	1560	-
Depth (mm) (steam: +125mm)	-	-	1225	-
Electric power with/without steam	-	-	9.4 / 6.6 kW	-

Modular deck oven 6 trays



Capacity	400 x 600	400 x 800	600 x 400	460 x 660
Baking slab width x depth (mm)	1240 x 1220	-	-	1420 x 1340
Baking area (m ²)	1.51	-	-	1.90
Width (mm)	1560	-	-	1740
Depth (mm) (steam: +125mm)	1745	-	-	1865
Electric power with/without steam	13.4 / 10.5 kW	-	-	13.4 / 10.4 kW

Technical data: combined ovens



Examples :

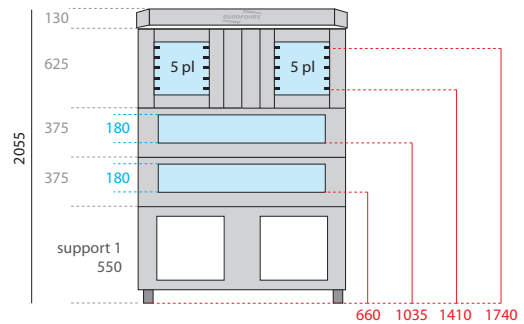
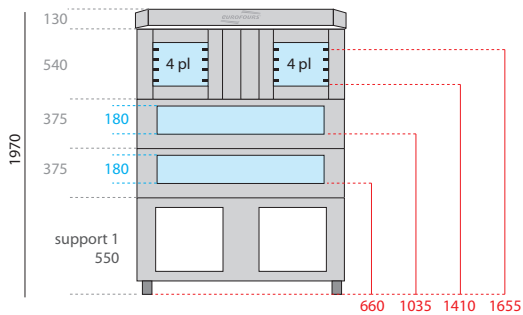
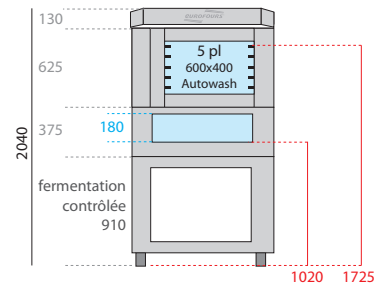
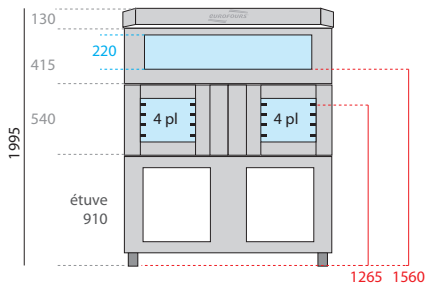

Base for modular deck ovens (mm) Spacing : 75mm

Trays format	400 x 600	400 x 800	460 x 800	600 x 400	460 x 660	660 x 460
Height (where 130mm of castors – adjustable feet from 90 to 130mm)	550 (optionally set of slides = 4 trays) or 780 (optionally set of slides = 6 trays)					
Width & depth	dimensions same as of the oven					

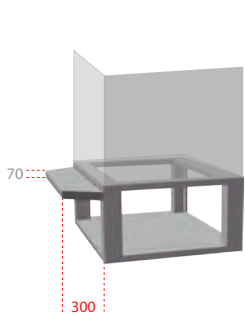

Base with worktop option

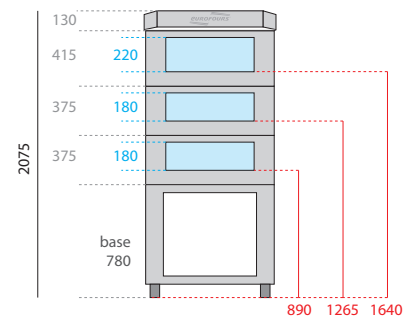
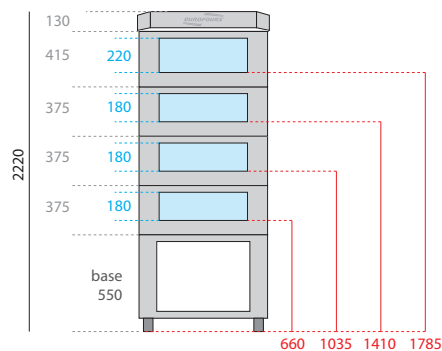

Your partner

